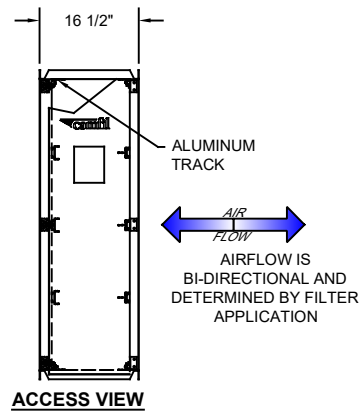
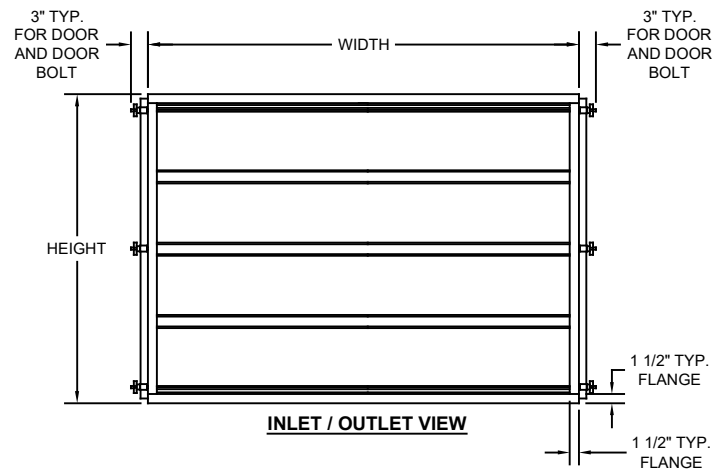
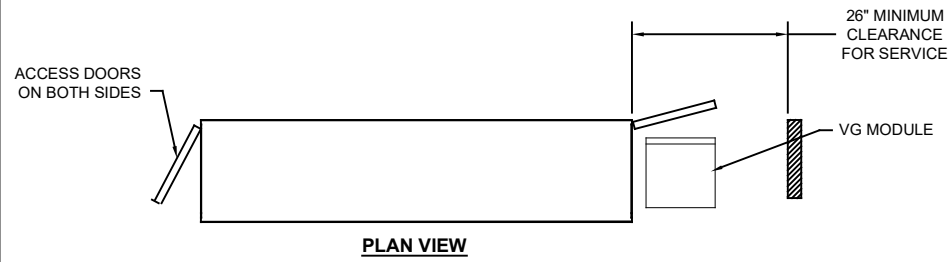

TABLE I - STANDARD UNIT AIRFLOW RATING		8	7	6	5	4	3	2	1
VG HOUSING SIZE WIDE		1/2	1	1-1/2	2	2-1/2	3		
WIDTH INCHES		11.75	23.50	35.25	47	58.75	70.5		
HOUSING SIZE HIGH	HEIGHT INCHES	AIRFLOW CAPACITIES (CFM), AT 250 FPM							
1/2	15.00	250	500	-	2,000	-	2,500		
1	27.13	500	1,000	1,500	2,000	2,500	3,000		
1-1/2	39.25	-	1,500	-	3,000	-	4,500		
2	51.38	1,000	2,000	3,000	4,000	5,000	6,000		
2-1/2	63.5	-	2,500	-	5,000	-	7,500		
3	75.63	1,500	3,000	4,500	6,000	7,500	9,000		
3-1/2	87.75	-	3,500	-	7,500	-	11,000		
4	99.88	2,000	4,000	6,000	8,000	10,000	12,000		

TABLE II GP HOUSING OPTIONS	
OPTION	DESCRIPTION
VG300	STANDARD
VG300D	INSULATED DOORS
VG300I	FULLY INSULATED

- GENERAL NOTES:**
- UNIT IS COMPLETELY FACTORY ASSEMBLED. FOR CAPACITY REFER TO TABLE I.
 - STANDARD MATERIAL OF CONSTRUCTION: 16 GA. GALVANIZED STEEL HOUSING, EXTRUDED ALUMINUM TRACKS WITH FIN SEAL, NEOPRENE DOOR GASKET, ZINC PLATED HINGES/T-BOLT AND PHENOLIC KNOBS FOR POSITIVE DOOR SEALING.
 - HOUSING OPTIONS:
A. REFER TO TABLE II
 - ORDERING INFORMATION: SEE TABLE I AND II SPECIFY OPTIONS AND SIZE
EXAMPLE:

GP CamCarb VG300I * 2HX2W
 GP CamCarb Housing ———— * Housing Height X Width
 Options ———— *Material
 Blank = No Options Blank = Galvanized (standard)
 I = Fully Insulated 316 = 316/L Stainless Steel
 D = Insulated Doors



- PERFORMANCE NOTES:**
- STANDARD HOUSING OPERATING PRESSURE TO ±6" W.G. INTEGRITY OF HOUSING TO AMBIENT LEAKAGE IS LESS THAN 0.5% AT 3" W.G.
 - HOUSING ONLY OPERATING TEMPERATURE IS 200° F CONTINUOUS. MEETS NFPA 90A AND TESTED PER ASTM-E84.
 - INSULATION ON INSULATED UNITS IS 1" THICK AND IS RATED AT 0.25 - 0.30 "K" FACTOR.

CUSTOMER APPROVAL BLOCK

YOUR APPROVAL OF THIS PRINT AUTHORIZES CAMFIL TO PROCEED WITH MATERIAL PROCUREMENT, TOOLING AND PRODUCT FABRICATION. ANY CHANGES MADE AFTER APPROVAL MAY INCUR FURTHER EXPENSES TO THE CUSTOMER

OK AS IS OK WITH REVISIONS SEND REVISED DWG.

SIGNATURE/DATE _____

APPROVED BY:	DATE:	DRAWN BY:	DATE:
RLG	5/5/21	WAW	5/3/21



© Camfil <http://www.camfil.us>

DESCRIPTION
CAMFIL GLIDEPACK CAMCARB VG300 SALES DRAWING

SHEET	DRAWING NUMBER	REV.
1 of 1	M261 VG300	0